



Galaxy GRS



10/350

10/150

10/50

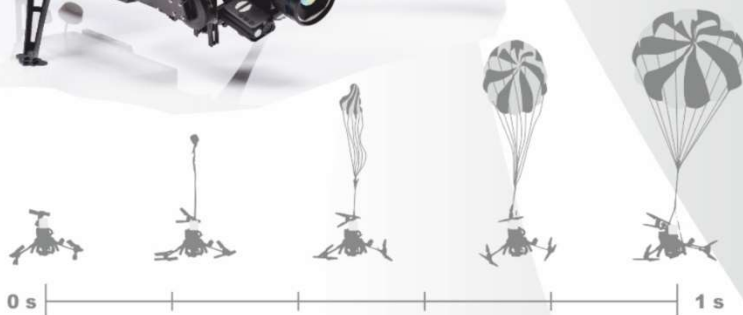

GALAXY GBS IO SERIES

UAV BALLISTIC RESCUE SYSTEM USER'S MANUAL

Galaxy GRS s.r.o. © 2024 rev 7 15.7.2024

1 INTRODUCTION

After more than three years of intensive development works by the company Galaxy GRS s.r.o. Liberec in cooperation with the Institute of aerospace engineering of the Brno university of technology and the company RCE systems s.r.o. supported by Indet Safety Systems a.s. we introduce you to a highly efficient ballistic rescue system **Galaxy GBS 10** for unmanned aerial vehicles (UAV). Thank you for trusting in us and we hope that you will never have to use the rescue system. We wish you a comfortable flight.

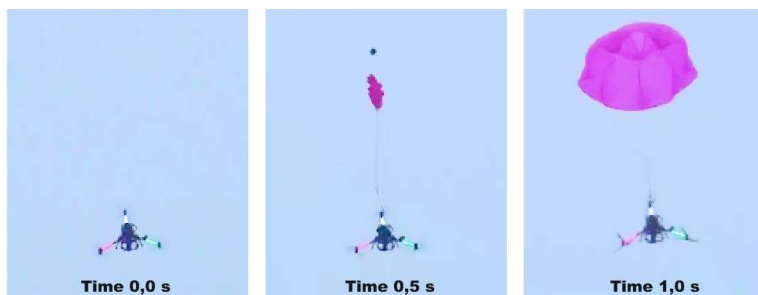

Function of GBS 10 system

Please review **FAQ** carefully:
<http://www.galaxysky.cz/faq-s123-en>



2 TECHNICAL PARAMETERS

TYPE	GBS 10/50	GBS 10/150	GBS 10/350	GBS 10/350 MOD 120	GBS 10/350 SPEEDY
Carrying Capacity	3-5 kg	5-15 kg	15-35 kg	15-35 kg	15-35 kg
Opening shock	250 N	800 N	1800 N	1800 N	2000 N
System Weight (±3%)	275 g	405 g	725 g	750g	770 g
Minimum Rescue Height	from 5 m			from 20m	From 30m
Speed	0-80 km/h			120 km/h	220 km/h
Way of Activation	Pyro-actuator 150		Pyro-actuator 350		
Time to Complete Filling of Canopy	up to 1 s			2 s	2,5 s
Operating Temperature	-20°C to +40°C (Version BASIC)				



FOUND OUT EASILY WHAT SYSTEM IS MOST SUITABLE FOR YOUR UAV – USE COMPUTER PROGRAM ON <https://www.galaxysky.cz/multicopters-s71-en>

TYP		GBS 10/50	GBS 10/150	GBS 10/350	GBS 10/350 Speedy
TOTAL WEIGHT INCLUDING RESCUE UNIT	kg	22.274	22.403	22.723	22.768
CALCULATED INFORMATIVE DESCENDING	m/s	10.5	7.5	4.3	4.3
THE CALCULATED IMPACT ENERGY	J	1231.3	627.5	202.5	202.6
CALCULATED DROP HEIGHT FOR TEST CHASSIS	m	5.7	2.9	0.9	0.9
<hr/>					
RECOMMENDED IMPACT ENERGY	J	48.0	48.0	110,0-500,0	110,0-500,0
Max. load of canopy at the limit of descent 6,5 m/s	kg	7.1	15.5	37.2	37.2

During demanding development the emphasis was placed, especially, on **reaching very high performances** to which the whole structural proposal, design as well as the production of ballistic rescue systems of series **GBS 10** were subordinated. **The system, namely, excels in:**

- **Minimum weight of rescue unit GBS 10/** in modifications **50, 150, 350, 350 Speedy**, each in the basic version **BASIC** and in the durable version **PRO** with CANBUS support.
- **The lightest** ballistic rescue system in the world in **the carrying capacities 5-35kg!**
- **Quick opening** of rescue parachute by means of the pyro-actuator **up to 1 second** after the system activation /the system like the airbag in the car/.
- **Range of application from 5 to 35 kg.** An ordinary speed range and guaranteed opening is from **0 to 80 km/hour. Versions 10/150 and 10/350 Mod 120 for speed up to 120 km/h and 10/350 Speedy up to 220 km/h**
- **Minimum rescue height** –the safety height of application already in the range **from 5 m above the ground.**
- **GBS 10/150 Mod 120 and 10/150 Mod 120** – the equipment is determined for faster flying models and drones up to the speed of **120 km/hour** with the time of opening **up to 2 second.** Minimum rescue height of this system is **20 m above the ground.**
- **GBS 10/350 Speedy** – the equipment is determined for fast flying models and drones up to the speed of **220 km/hour** with the time of opening **up to 2.5 second.** Minimum rescue height of this system is **30 m above the ground.**
- **Harm reduction** to your unmanned aerial vehicle, as well as **increased security on the ground** in the operational area of UAV.
- **Multiple system use** – simple process of putting the rescue unit into the operating status immediately after its field use in a very short time. **Galaxy does not guarantee the correct functioning of the GBS10 system if the repacking and assembly of the system after activation was performed by the user. Galaxy offers the option of repacking and checking the system directly at the factory or REFILL SETS with new cap and piston.**
- **Usable range** for the system activation is identical with the range of your RC equipment.
- Ballistic equipment has undergone long-term testing in the **Institute of Aerospace Engineering VUT Brno** and it is **certified by the aviation testing laboratory.**



- Parachutes were designed on the basis of **measurement results in the aerodynamic tunnel in the Aerospace Research and Test Establishment (VZLÚ) Letňany** in order to reach the maximum stability and optimization of coefficient of resistance C_x .
- Developed unit is protected by two patents and several utility models filed on the ballistic rescue system itself and the parachute.
- **Easy installation** of ballistic equipment and electronics on any UAV system.
- The device can be optionally supplied with **Engines Cutter** to switch off the UAV engines with regard to the status of the safety lock and the parachute. **It serves to switch between the primary and backup flight control systems.**
- **Safety interlocking** for the transport of prepared **UAV** with an installed unit, as well as individually transported units with the installed **safety shorting fuse** and the light and acoustic indication for the unit Stand-By mode before take-off.
- **Service** and production of the unit in **Galaxy Holding in Liberec** – the company with **30 years tradition** with parachute ballistic systems.

3 SAFETY RULES

When handling the system and also during its use always pay increased attention and observe following **SAFETY RULES**. Their omission or failure to comply with may result in the bodily injury or property damage.



- **Before handling the ballistic rescue system always disconnect the power source.**
- **Before handling the ballistic rescue system always lock the system by means of shorting fuse.**
- **Ballistic rescue system prepare for operation just prior to take-off. In case you want to manipulate with system, disconnect the power supply and repeat the initialization procedure.**
- **During system charging always use protective glasses and gloves.**
- **Check the entire system before the power source is connected.**
- **Use training pyro for system test and easy development (emulates real pyro by LED).**
- **When powering system be sure activation signal is not alive / present**
- **Never lean over the container with the pyro-actuator.**
- **Never point the container with the pyro-actuator either against any person or against yourself.**
- **Before flying trigger the system by pulling out the shorting fuse.**



- Pay increased attention during the flight.
- Lock the ballistic rescue system by means of the shorting fuse after landing. Then disconnect the power source.
- Always lock the ballistic rescue system by means of the shorting fuse during storing.
- Always lock the ballistic rescue system by means of the shorting fuse during transportation.
- The shorting fuse is the only and safety way how to prevent an intended or unintended system activation (launching the emergency parachute).
- Do not operate the system in close vicinity of potentially explosive area, for example, gas pipelines or gas storage, etc.
- For charging of system GBS 10/350 always use pyro-actuator 350 only!

In inappropriate or improper handling an unexpected activation of the control module and launching the emergency parachute may occur. Pay increased attention during using or handling the system. Check regularly electronic modules (cabling, connectors and their any possible damage). Check the mounting of the system and electronic module to the airframe before each flight.

Connect electronic modules only according to the manufacturer's instructions.
The manufacturer is not liable for any damage caused by improper handling!



The product, when properly installed and when used in compliance with the procedure for handling and storage, reduces significantly the likelihood of UAV and airborne equipment damage in case of UAV failure. In any case the user is not entitled to infringe legislative restrictions for the operation of unmanned aviation vehicles, for example, in densely populated areas, etc. Even despite the small planned impact energy the product is not capable with 100% probability to prevent any damage caused by the unmanned aerial vehicle crash. Observe the national legislation for the operation of your UAV. GBS 10 product is based on using the latest technology and components applied in aerospace, space and automotive industries. Like an airbag in a car reduces significantly the consequences of eventual traffic accident, but is not able to prevent injuries

in all cases and does not entitle the driver not to obey the law, the GBS 10 system enhances security payload in your UAV and reduces the risk of damage during the fall. The system, however, is not able to completely prevent any damage or injury, and the manufacturer is not liable for them.

Galaxy Holding s.r.o. as a seller is not liable for any damages or injuries resulting directly or indirectly from the use of this product, or any other possible damages arising from the fall or operation of the unmanned aerial vehicle!

Galaxy GBS10 is a one part of the complex safety mechanism of each UAV and fulfills a role of secondary emergency device. It is not a landing device.

4 PACKAGE CONTENT

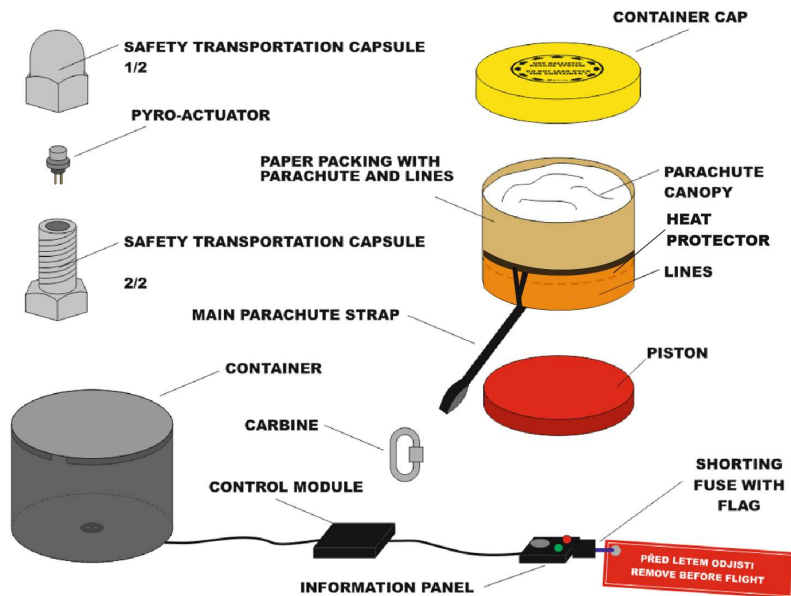

Note about piston: we make design change in 2020 to unify design of piston. Please review **Annex No. 5 (GBS 10 design change)** to clarify if impact you



5 SYSTEM CHARGING AFTER UNPACKING

- 1) Each system charging should be carried out in the **dry surroundings!** Unscrew the safety transportation capsule and **take out the pyro-actuator - when taking out the pyro-actuator from the transport capsule you are obliged to use protective glasses and gloves.** Before handling we recommend to ground both the safety capsule and the hands by grasping the capsule by hand and putting the hand with the capsule on the grounded object (such as a grounded table, space heater, metal body of water taps, possibly also on soil or grass) and to keep in the contact for the period of minimum **3 seconds**. The complete information can be found in **Annex No. 1**
- 2) Insert the pyro-actuator into the socket in the bottom of the container and then insert the piston. **Observe SAFETY RULES (see Chapter 3)!**

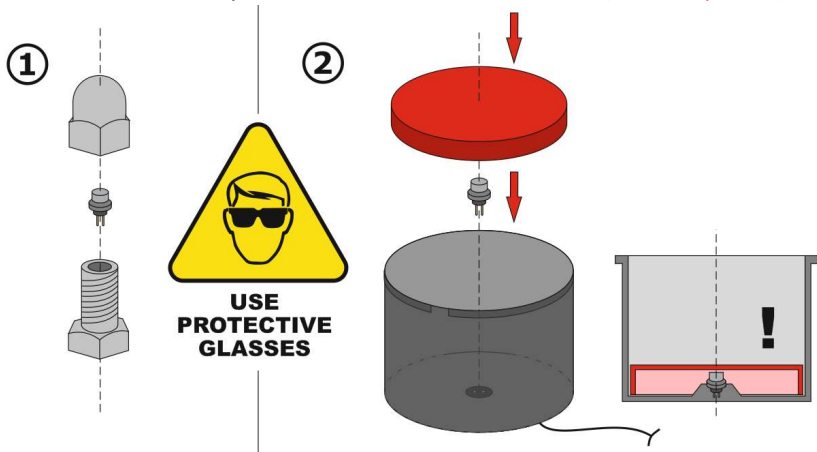

- 3) **Remove the lower embedding cap of the container.** Attach the paper packing on the container top and squeeze the parachute with lines **covered by heat protector** through this packing inside the container. Heat protector reduces the risk of burning the cords during repeated use. Direct the main parachute strap into the groove in the reinforced upper edge of container rim and leave its end outside the container for the carbine connection.
- 4) **Remove the paper packing,** put on the container cap on the cylinder top.



- 5) **Fasten the container** as close as possible to the centre of your UAV to rigid surface by means of Velcro fastener or initially by **bolts described in Anex No.4**. The rearward thrust generated when a parachute is being deployed is equivalent to the 15kg for GBS10/150 (200ms pulse) and for the 20kg for GBS10/350 (200ms pulse).

Above the container shall be no obstruction that would prevent the safe deployment of the parachute. **Any additional fuselage covers placed over the container cap are strictly prohibited.**

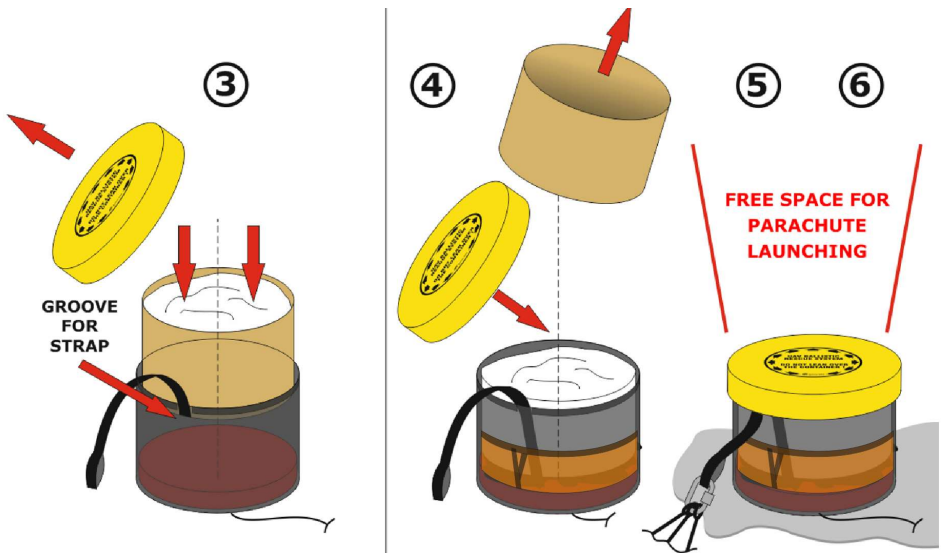

- 6) **Connect the end of the main parachute strap with the suspension system** (system of straps, ropes, etc.) **by means of carbine**. The UAV should descend in the horizontal position.
- 7) Fasten the information panel with the shorting fuse so that the **shorting fuse is in the conspicuous and accessible place**.
- 8) Fasten the container on your UAV by means of the Velcro
- 9) Always install container aiming to the top to ensure parachute will be fired above the UAV



Heat protector location

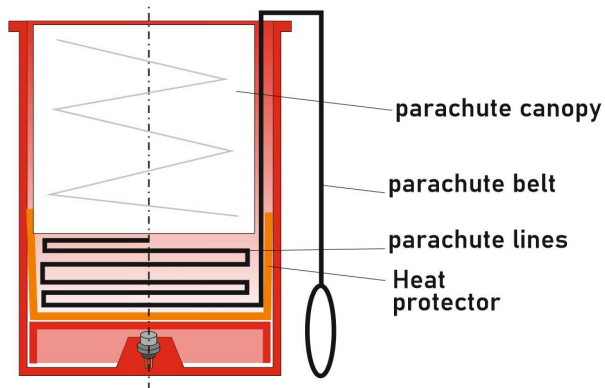

6 ELECTRONIC SYSTEM

Instructions for electronic system installation can be found in separate manual which is included in the package and its version varies according to the type of control electronics supplied (BASIC, PRO, A3CONNECT, DJI2GBS...). Note also training pyro, emergency buzzer and engine cutter.

7 SYSTEM RECHARGING AFTER ITS ACTIVATION

After each use of the rescue system it is necessary to check all parts of the assembly, mainly the cylinder, piston and electronic modules including their interconnection **see Chapter 9**. In case of any damage contact the manufacturer. In case the system is without any damage, you can start to recharge it. Make the record in the table - **Annex No. 3**.

Observe SAFETY RULES (see Chapter 3)! It is strongly recommended to use new piston and cap as reusing of used parts can increase a risk of improper function in case of incorrectly reinstalled/refolded parachute. Galaxy does not guarantee the correct functioning of the GBS10 system if the repacking and assembly of the system after activation was performed by the user. Galaxy offers the option of repacking and checking the system directly at the factory or REFILL SETS with new cap and piston.



7.1 System Recharging Procedure

- 1) Remove the used pyro-actuator from the socket in the bottom of container.
- 2) Unscrew the safety transportation capsule and take out the new unused pyro-actuator – when taking the pyro-actuator out, observe the rules according to **Chapter 5 Item 1**).
- 3) Insert the pyro-actuator into the socket in the bottom of container and then insert the piston. **Observe SAFETY RULES (see Chapter 3)!**
- 4) Pack the parachute with lines carefully according to **Chapter 7.2**.
- 5) Insert the carefully folded lines inside **heat protector** and then into the container. Be sure that heat protector protects all lines and fills the bottom of canister completely. Direct the main parachute strap into the groove in the reinforced upper edge of container rim and leave its end outside the container for the carbine to be connected. Press the folded parachute gradually with your hands – the best with thumbs – inside the container in the form of „harmonica“, starting from the bottom part of parachute according to figure 5.
- 6) Put the cap of container on its top
- 7) Fasten the container back on your UAV by means of the Velcro fastener in case that the container is not attached by screws on the bottom.
- 8) Connect the end of the main parachute strap with suspension straps by means of the carbine.
- 9) The system is charged and prepared for the next use.



②



③



**USE
PROTECTIVE
GLASSES**

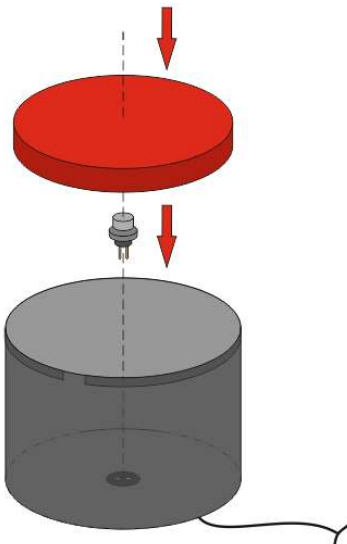

⑤

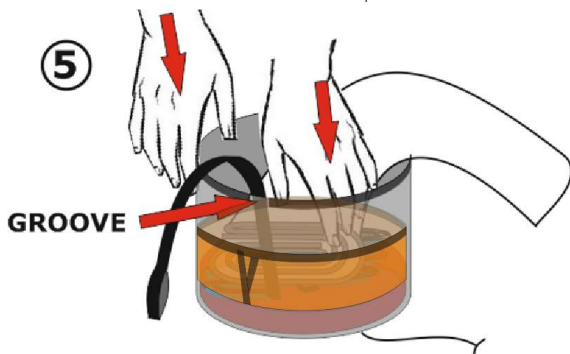

⑥



⑤

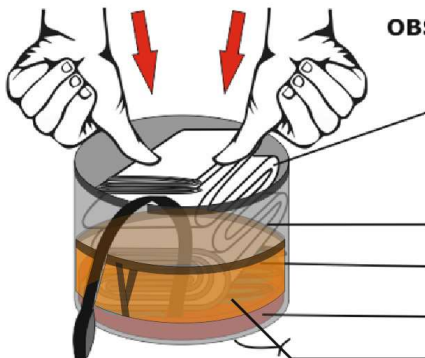

**OBSERVE THE STRUCTURE
OF FOLDS**



FOLDED PARACHUTE

FOLDED LINES

PISTON

HEAT PROTECTOR



7.2 Parachute Packaging

- 1) Check whether **there was no damage on the parachute, lines or the main parachute strap** during the rescue of your UAV. Make sure that the lines are loose (they do not cross) and tighten them all (including the central line leading to the upper parachute opening). Thus the upper part of the parachute falls inside the parachute. Check whether the parachute is not damp or wet.
- 2) The parachute has 7 (10/50 & 10/150) or 14 (10/350) cells. Fold each cell in half so that all the lines come out from the centre of the parachute and divide the folds in the ratio 3:4.
- 3) Fold the tighten and aligned lines in the form of „harmonica“ and lock them together with a thin rubber band according to the figure. Do not fold the rubber band – rather looser enlacement! The length of folds should be approximately equal to the container diameter. In case of repacking of GBS 10 version MOD120 or Speedy, **see annex No.6**

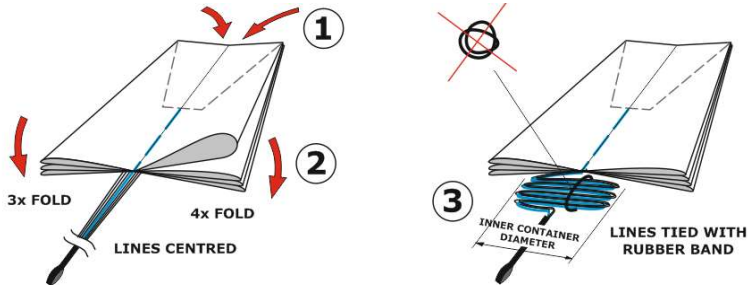

- 4) 2/3 of the **left** folds fold toward the center of the parachute.
- 5) 2/3 of the **right** folds fold toward the center of the parachute, but on the opposite side. Lines must still be centered relative to the **parachute**.

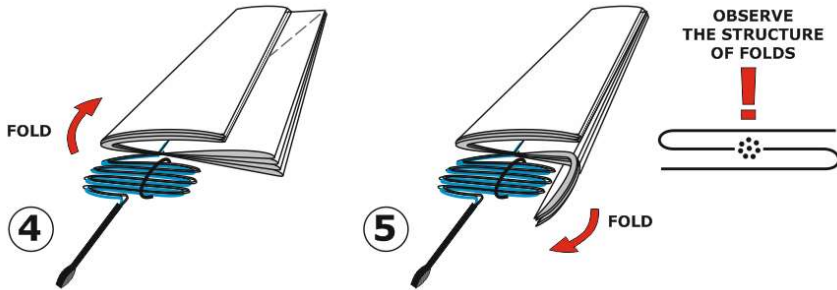

- 6) The left and right part of folded parachute fold over each other according to Figure 6. It is important to **preserve the structure of folds**! Now the parachute is ready to be pressed into the container. Continue in the procedure with **Item 5) in Chapter 7.1**

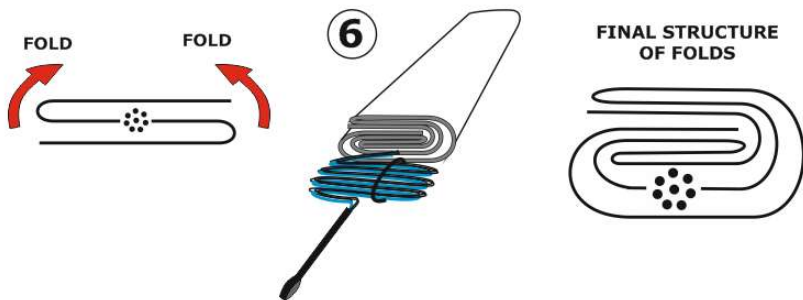

You can always check video about folding at <http://www.galaxysky.cz/manuals-s120-en>



8 PROCEDURE FOR SYSTEM FAILURE

Despite of all the efforts put into the reliability of the system in the course of its development, absolutely exceptionally a situation may occur when the system does not respond to the transmitted signal to activate it. In such a case proceed according to the following steps. It is necessary to identify the cause of failure. The pyro-actuator itself is tested with extreme requirements as to its reliability and therefore it is necessary to exclude other more likely potential causes of system failure before its disassembly. If the crash of the unmanned aerial vehicle with the ballistic rescue system on board takes place, be very careful upon the



inspection after UAV hitting the ground. Keep away from the system in the direction of potential parachute launching, i.e. in the direction towards the container cap.

Do not switch off the RC transmitter before coming to the wireless UAV equipment. After coming to UAV check the information panel – whether it signals the system running (blinking of green/red diode, possibly acoustic signalling). Make note of this information. Only then disconnect the power source from the unmanned aerial vehicle and subsequently the RC transmitter.

- 1) Check whether the shorting fuse was removed before the take-off. If not, the system was OK.
- 2) In case the control module and information panel have not been mechanically damaged, disconnect it and subsequently check the function of both modules according to Items 6.4 and 6.5 of this User's Manual. Provided the unit responds to the signal for launching according to Item 6.5, the control unit is OK.
- 3) In case any of the modules has been damaged, send it to the manufacturer with the description of the event.

In case no cause of failure has been found out during the inspection carried out according to Items a) and b), it is necessary **to dismantle the pyro-actuator** from the system and send it to the manufacturer in the original packing. The procedure of dismantling is as follows:

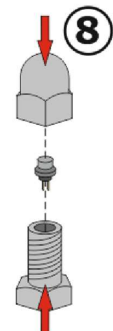
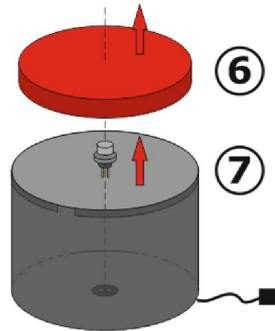
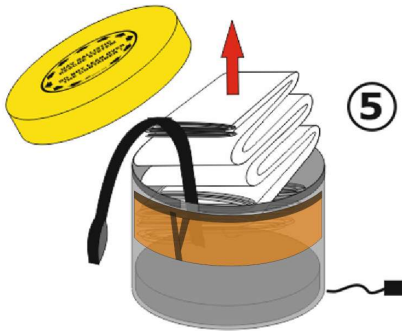
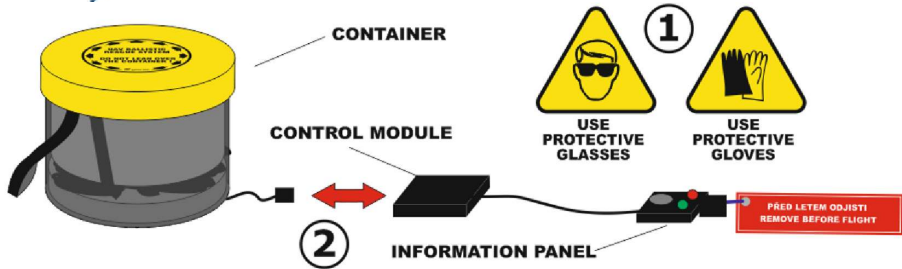

- 1) Prepare protective glasses, gloves and the tool for removing the pyro-actuator (combination pliers as the best).
- 2) Disconnect the control module from the rescue system (connector PYRO)
- 3) Make access to the container with the rescue system. **DO NOT LEAN OVER THE CONTAINER!**
- 4) Remove the container cap.
- 5) By gradual pulling remove the packaged parachute from the container.
- 6) Remove the piston from the container.
- 7) Using the pliers remove the pyro-actuator carefully from the socket.
- 8) Insert it to the safety transportation capsule and lock it by screwing.
- 9) Send the pyro-actuator to the manufacturer.



9 WARRANTY AND CONSUMER TIME

Warranty period is two years from the purchase of GBS10 system. The date of purchase and date of manufacture of the ballistic rescue system are marked out in the warranty certificate with QR codes for manuals.

Service life – The system is possible to be used repeatedly if the mentioned conditions are met. In the course of testing the rescue unit was loaded with a series of seven launches without any damage. To ensure the proper function of the ballistic rescue system, it is necessary to carry out regular inspections of all parts of the assembly not only after launching, but also during the use of the unmanned aerial vehicle (influence of vibrations, dynamic impacts when landing, etc.)

The manufacturer recommends carrying out the inspection of these parts:

PREVENTIVE INSPECTION	INSPECTION AFTER SYSTEM ACTIVATION
<p>1) Electronic modules – inspection of cables, plugging of connectors and their possible damage</p> <p>2) Fastening of the system and electronic module to the UAV airframe</p> <p>3) Joining the main parachute strap with the suspension system (straps, lines)</p> <p>4) Inspection of the suspension system in the UAV suspension points</p> <p>5) In the direction of the rescue parachute launching shall be no obstruction or, for example, part of installed on-board equipment or any cables</p> <p>6) Inspection of container cap closure tighten with the Velcro fastener</p>	<p>1) Detailed inspection of the internal and external parts of container</p> <p>2) Piston inspection</p> <p>3) Parachute inspection</p> <p>4) Inspection of parachute lines and the main parachute strap</p> <p>5) Inspection of suspension system – possible damage from rotors</p> <p>6) After recharging – all steps from the preventive inspection</p>

In case of any damage or doubts do not hesitate to contact the manufacturer.

Spare parts and accessories may be purchased directly from the manufacturer or your dealer.



10 STORING

Optimal storing temperature is **14 –24 °C** with air humidity 35-73%! Ballistic rescue system is designed for the limiting values of use from **–20°C to +40°C!** Nevertheless, we cannot recommend permanent exposition of the system to these temperature and exceeding **the recommended humidity values** during storing!

The manufacturer prohibits to expose the system to high temperatures, hard impacts, mechanical damage, acids, aggressive chemicals, long-term storing in excessive humidity and permanent vibrations!

Warning – The system must be handled as pyrotechnic equipment and any person is prohibited to move in the direction of parachute launching, or to aim at his own body with the unlocked system!

11 TRANSPORT

The safety transportation capsule serves for the safety transport of individual pyro-actuator pieces with the maximum portion of pyrotechnic charges up to 500mg and in compliance with the documentation ISV 2198, according to which the capsules were certified by the notified European testing laboratory (No. 1395, Konštrukta Defence a.s., Slovakia). Thanks to this it is possible to transport the product by means of the classical mail as the explosion-proof (safe) equipment. Based on fulfilling the prescribed legislative UNO conditions for declassification of the product from the exclusive Class 1 for the transport of dangerous goods there was issued Resolution No. SK/KTD018/14 the copy of which you may find in **ANNEX NO. 2**. Declassification allows transport product by ground transport only, it is declassify from ADR Dangerous goods. Without using of this capsule is pyroactuator handled as dangerous goods class ADR 1.4S.



ANNEX NO. 1 – Safety Transportation Capsule for the transport of pyro-actuator – manufacturer ISS a.s. and PYRO DISPOSAL AND LIFE-SPAN



Indet Safety Systems

Use

Safety transportation capsule is used for the safe transportation of individual ISS's pyrotechnic products with the maximum amount of pyrotechnical charges up to 500mg and in compliance with the documentation ISV 2198 submitted to the certification process by European Notified Testing Laboratory (No. 1395, Konštrukta Defence a.s., Slovakia). Based on fulfilling the prescribed UNO legislative requirements for the declassification of dangerous goods from Class 1, there was issued Resolution No. SK/KTD018/14.

The copy of this document must be attached to each delivery of products in the safety transportation capsules.

Description of Product and Safety Measures:

Safety transportation capsule is composed of screw body with an internal cavity for installation of non-detonating pyrotechnic article and of threaded cup. The cup and body are screwed tightly together using 2 spanners or other suitable tools. Subsequently the capsule containing the squib is packed and as a standard mail delivery can be transported by standard delivery services like Post as non-dangerous goods. Attention! This information is not valid for the U.S. territory where an additional approval from DOT is required. Filling of capsules with squibs is done by the manufacturer.

Upon removing the squib from the safety capsule always wear protective glasses (dioptric or sun glasses are enough). We recommend effectuate grounding of safety capsule and operator's hands by touching grounded metal objects (like grounded metal table, space heater, metal body of water taps, possibly also on soil or grass) and to keep in the contact for the period of minimum **3 seconds**. After this procedure you can disassemble the safety capsule by means of two socket spanners or other suitable aids and remove the pyrotechnic squib for the next use.

The safety transportation capsule may be used repeatedly (as returnable packaging) provided that in terms of using it is not excessively worn out, or corroded, which prevents easy disassembly or safety removal of its content. When the product is removed from the safety capsule, it is again categorized as a pyrotechnic article for other uses of category P1 (with low hazard) in compliance with the valid regulations of the



European Union. Its acquisition, handling or use could be treated under the specific legislation in the country of use. Fulfilling of these requirements is always a responsibility of the distributor and user of our products.

Important additional information:

Attention! The use of safety capsule does not exempt from the obligation to observe the legislation for the pyrotechnic articles in the user's country. The safety capsule is only the approved means for the safety transportation of pyrotechnic articles! Indet Safety Systems a.s. prohibits all and any adjustments of safety capsules. Any other use than prescribed and approved of is strictly prohibited. In case of any breach of these regulations and instructions mentioned above the company Indet Safety Systems a.s. assumes no responsibility for the caused damage. If needed, please, contact us at phone No. +420 571 425 001 or by e-mail info@iss-cz.com.

Pyro disposal

- 1) By activation – activation of the complete GBS10 unit on ground – activate the GBS system remotely from safe distance.
- 2) By sending back to producer as described in chapter 8

Pyro life-span

Product warranty is 24 months from date of sale, or 100 flight hours (whichever comes first).

Estimated minimum lifespan is 5 years or 100 flight hours (whichever comes first).

**ANNEX NO. 2**

KONŠTRUKTA – Defence a.s.
Prevádzka špeciálneho skúšobníctva, 018 41 Dubnica nad Váhom
Autorizovaná osoba SKTC – 112

ROZHODNUTIE č. SK/KTD018/14
Resolution № RZ – SK/KTD018/14

o deklasifikácii nebezpečných vecí triedy 1 – Výbušniny v zmysle Európskej dohody o medzinárodnej cestnej preprave nebezpečných vecí (ADR).
on declassification of dangerous goods of Class 1 – Explosives in sense of International Transportation of Dangerous Goods by Road (ADR).

Toto rozhodnutie sa vydáva na základe poverenia Ministerstva dopravy, pôšt a telekomunikácií Slovenskej republiky č.j. 9 – 101/2003 zo 07. 02. 2003 a na základe žiadosti spoločnosti:

This resolution is issued according to the authorisation by Ministry of Transport, Posts and Telecommunications of the Slovak Republic № 9 – 101/2003 dated 07.02.2003 and on the base of application of the company:

Indet Safety Systems, a.s.
Bobrky 462
755 01 Vsetín
Česká republika
Czech republic

Názov látky alebo predmetu: **Nedetonujúce pyrotechnické predmety s hmotnosťou pyrotechnickej zlože do 500 mg**
Name of the substance or article: Non-detonating pyrotechnic articles with weight pyrotechnic composition up to the 500 mg

Výrobca: **Indet Safety Systems, a.s.**
Manufacturer: **Bobrky 462**
755 01 Vsetín
Česká republika
Czech republic

Nedetonujúce pyrotechnické predmety s hmotnosťou pyrotechnickej zlože do 500 mg, v transportom puzdre, ktoré je vyrobené podľa dokumentácie ISV 2198, sú vyňaté z UN triedy I pretože nepredstavujú značné nebezpečenstvo výbuchu v súlade s „UN Recommendations on the Transport of Dangerous Goods - Model Regulations, Seventeenth revised edition 2011“ bod 2.1.3.6.4.



Non-detonating pyrotechnic articles with weight pyrotechnic composition up to the 500 mg.in transport housing, which is made according to documentation ISV 2198, are excluded from UN Class 1 and designated as not presenting a significant hazard from explosion in accordance with „UN Recommendations on the Transport of Dangerous Goods - Model Regulations, Seventeenth revised edition 2011“ point 2.1.3.6.4 .

Vyššie uvedená deklasifikácia platí tiež pre dopravu výbušnín podľa IMDG, ICAO TI, RID a ADN.

The above mentioned declassification is also valid for transport of explosives according to IMDG, RID, ICAO TI and ADN.

Dátum a miesto vydania: 11. 12. 2014, Dubnica nad Váhom

Date and place of issue:



Ing. Daniel Nemček
riaditeľ SKTC – 112
Director of SKTC – 112

063581



ANNEX NO. 3 – RECORD OF SYSTEM USE

The manufacturer recommends recording every use of the system including the entire system inspection carried out, especially, in case that the unmanned aerial vehicle is operated alternatively by more persons.

NUMBER OF USES	DATE	INSPECTION CARRIED OUT	SIGNATURE
1.			
2.			
3.			
4.			
5.			
6.			
7.			
8.			
9.			
10.			



ANNEX No 4 (Instruction for GBS 10 Attachment):

Attach the GBS10 canister by 2x bolt as on the picture below or by using Velcro system or 3M Dual lock system

TOP VIEW

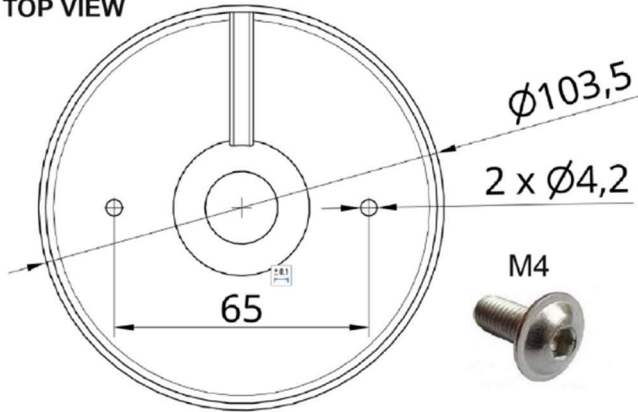

Install the system on rigid support from the bottom of the GBS 10 canister



Do not tie the canister by any plate clamps the shape of the cylinder can change and cause blocking of the piston and incorrect deployment

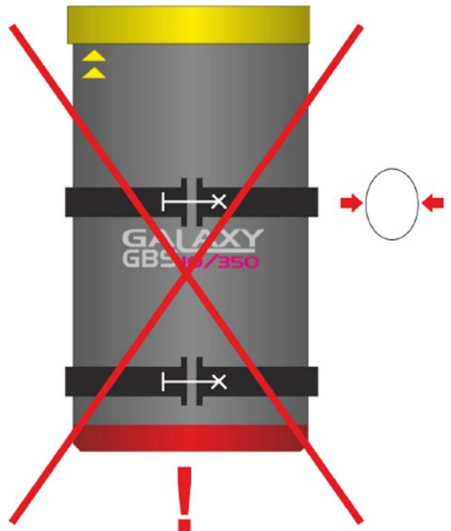



ANNEX No 5 (GBS 10 Design change):

We had two different pistons, one flat for GBS 10/50 and 10/150 and one curved for GBS10/350. You can see situation (before 2020 year change) in picture (GBS 10/350 on left, GBS 10/150 on right):



From end of 2020 we have changed design of GBS 10/350 to accept same piston as is in GBS 10/150, so, all our systems (10/50+10/150+10/350 including Speedy and MOD120 variants) now uses same piston.

To visually separate the pistons and the systems that belong together, the old 350 systems are white (with a red bottom) and include a white curved piston. The new 350 systems are then all red and include a red straight piston. This is the same as with the GBS 10/150 (red container and red piston) where no change occurs. See picture:



If you have curved piston from previous orders, it may be red but curved and possible to use only in old design 10/350 (white).

Please note how to be piston (both old and new version) inserted correctly:

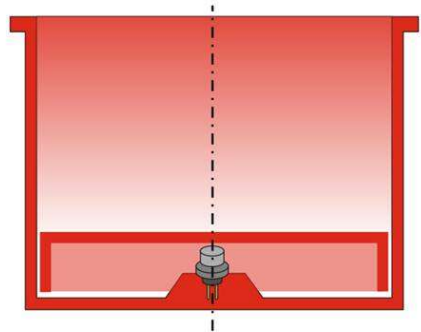
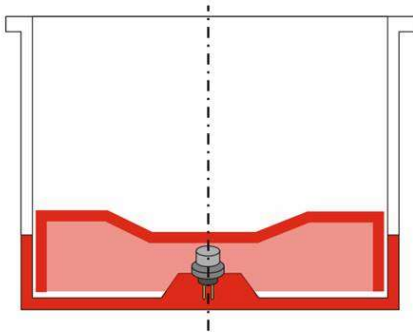



ANNEX No 6 (Slider arrangement):

MOD 120

Parachute repacking is the same as described in regular manual, but this customized parachute for 120 km/h has special black slider ring* which has to be folded according to picture below. Slider is folded on the top of lines, then is 150 mm of free lines and then the rest of lines can be folded and tied with 1x rubber band provided by Galaxy.

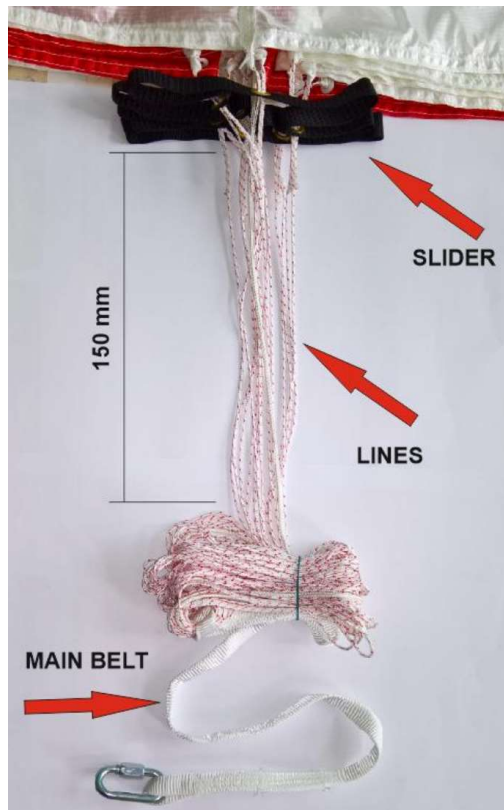

In case that the system is used on maximum weight/speed conditions, must be checked by Galaxy GRS.

*Slider ring is an auxiliary part of the parachute, a ring that allows to increase the usable speed of parachute application by spreading the parachute braking process over time.



SPEEDY

Parachute repacking is the same as described in regular manual, but this customized parachute for 220 km/h has special fabric slider ring*, which has to be folded according to picture below. Slider is folded on the top of lines, and then the rest of lines can be folded and tied with 1x rubber band provided by Galaxy. Parachute has 14 lines, slider has 12 segments, so 2 slider holes contains 2 lines, the rest only one, as you can see from the picture. During folding keep those 2 slider holes one on top and one on bottom.



In case that the system is used on maximum weight/speed conditions, must be checked by Galaxy GRS.

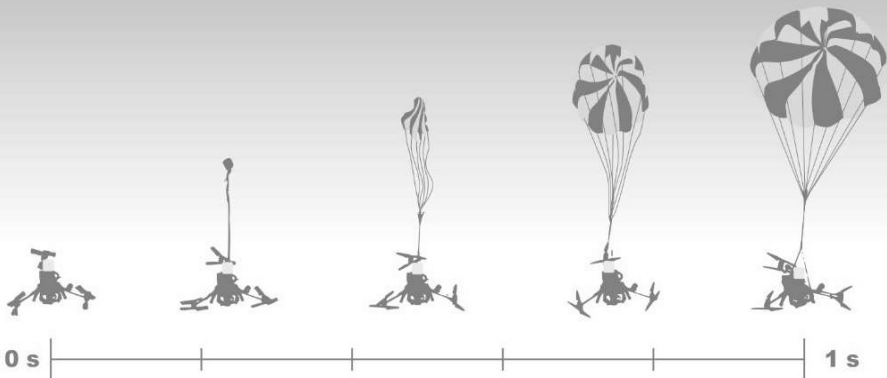

**RESCUE YOUR UNMANNED
AERIAL VEHICLE WITH
THE GALAXY GBS 10
UP TO 1 sec.**



GALAXY

**Třída 1.máje 24/a
460 01 Liberec 3
Czech Republic**

www.galaxysky.cz